

HIBLOW®

Powerful Eco & Smart

XP series

XP-40

XP-60

XP-80



- ▶ **World's smallest and Lightest**
** 80L class of electric blower for waste water treatment*
- ▶ **Low Power Consumption**
- ▶ **Dust Control : "Dust Trap Filter"**
- ▶ **Low Noise Level**
- ▶ **Easy Maintenance**
- ▶ **Dual Insulation (No need of grounding)**



Powerful Eco & Smart XP series

XP-40
XP-60
XP-80

Dust Control "Dust Trap Filter"

"Dust Trap Filter" is realization of the structure which exert the effect of dust control by analyzing airflow and the speed with computer analysis!!



Easy Maintenance

- ▶ **Detachable built-in block**
Very easy to replace
Chamber Block,
Diaphragm Block, Rod

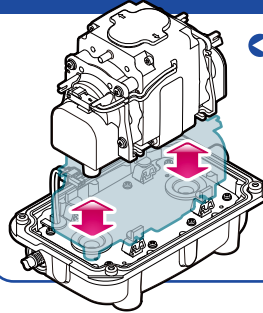

- ▶ **Easy restart by micro switch**
*XP-60 / 80 only



Performance Curves

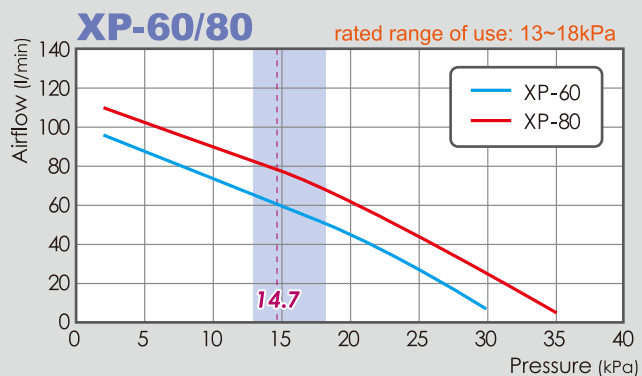
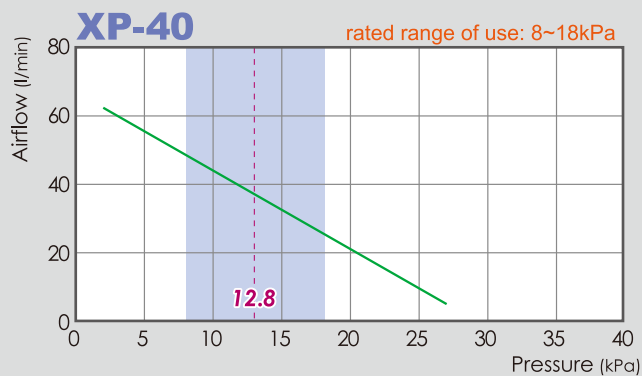

*Above graphs are reference for catalogue
*Power consumption is the data based on 230V

Specifications

		XP-40	XP-60	XP-80
Rated Voltage	V	220 - 240		
Power Supply Frequency	Hz	50		
Power Consumption	W	30	39	58
Rated Loading Pressure	kPa	12.8	14.7	
Airflow Volume	l/min	40	60	80
Noise Level	dB(A)	33	35	36
Weight	kg	4.1	4.3	

*Above data is reference for catalogue

Dimensions

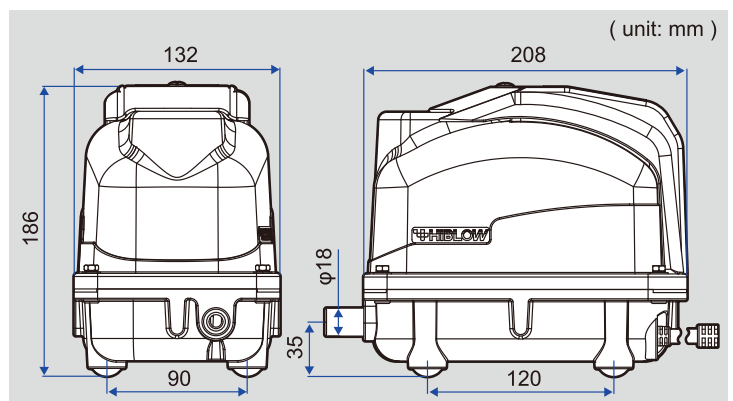

TECHNO TAKATSUKI CO.,LTD.

HEAD OFFICE,
International Marketing Group
8-16, Haccho-Nishimachi,
Takatsuki, Osaka 569-0095
TEL +81-72-684-0805
FAX +81-72-684-0807

<http://www.takatsuki.co.jp/>

HIBLOW FRANCE S.A.S
15 Rue Taitbout 75009 Paris France
TEL/FAX +33-1-61-37-09-15

HIBLOW SPAIN S.L.
Apartado de Correos N° 118 28830
San Fernando de Henares, Madrid, Spain
TEL/FAX +34-91-669-3953

HIBLOW KOREA INC.
大韓民國仁川市西區佳佐洞 469-3 泰興精密內
469-3, Gazwa-dong, Seo-gu, Incheon City, Korea
TEL +82-032-873-8901 / Fax +82-032-873-8903

Distributor